



Cat. No. 62029-18

APA 6000™ High and Low Range Copper Process Analyzer

Operation Manual

Table of Contents

| | |
|---|-----------|
| Safety Precautions | 3 |
| Specifications | 4 |
| Operation | 5 |
| Section 1 Instrument Overview | 6 |
| 1.1 How to Use the Manuals | 6 |
| 1.2 General Description | 6 |
| 1.2.1 Instrument Enclosure..... | 6 |
| 1.2.2 Autoburette Module | 6 |
| 1.2.3 Colorimeter Module and Holding Coil..... | 7 |
| 1.2.4 Rotary Valve Module | 7 |
| 1.2.5 Mixer Module | 7 |
| 1.2.6 Plumbing Diagram and Tubing Lengths..... | 7 |
| 1.2.7 Vortex Sample Conditioning Block..... | 8 |
| 1.2.8 Copper Reagents | 8 |
| Section 2 Theory of Operation..... | 10 |
| 2.1 Method of Analysis..... | 10 |
| 2.2 Reagent and Standard Consumption..... | 11 |
| Section 3 Parameter Specific Menu Functions..... | 12 |
| 3.1 Calibration History..... | 12 |
| 3.2 Measurement Options..... | 12 |
| Section 4 Sequence of Instrument Events | 13 |
| Section 5 Bench Comparison Testing | 17 |
| 5.1 Comparable Bench Methods..... | 17 |
| 5.2 Bench Method Procedure | 17 |
| 5.3 Determining Copper Concentration in Samples..... | 19 |
| Section 6 Replacement Parts | 20 |

Please read this entire manual before unpacking, setting up, or operating this instrument. Pay particular attention to all danger and caution statements. Failure to do so could result in serious injury to the operator or damage to the equipment.

To ensure the protection provided by this equipment is not impaired, do not use or install this equipment in any manner other than that which is specified in this manual.

Use of Hazard Information

If multiple hazards exist, this manual will use the signal word (Danger, Caution, Note) corresponding to the greatest hazard.

DANGER

Indicates a potentially or imminently hazardous situation which, if not avoided, could result in death or serious injury.

CAUTION

Indicates a potentially hazardous situation that may result in minor or moderate injury.

NOTE

Information that requires special emphasis.

Precautionary Labels

Read all labels and tags attached to the instrument. Personal injury or damage to the instrument could occur if not observed.



This symbol, if noted on the instrument, references the instruction manual for operation and/or safety information.



This symbol, if noted on the product, indicates the need for protective eye wear.

Specifications

Specifications are subject to change without notice.

See instrument-specific specifications in the APA 6000™ Installation and Maintenance Manual, Cat. No. 62005-18.

Performance

Range: 0.05 to 10 mg/L Cu²⁺

Accuracy:

Low range (optimum from 0.03 to 1.00 mg/L): ±3% or ±0.03 mg/L, whichever is greater.

High range (optimum from 1 to 10 mg/L): ±5% or ±0.05 mg/L, whichever is greater.

Repeatability: ±3% of reading or ±0.03 mg/L, whichever is greater

Response Time: For single channel instruments, less than 5 minutes for 90% response to step change at sample inlet.

Cycle Time: 4.5 minutes (average)

Sample Temperature Range: 5 to 40 °C (41 to 104 °F)

Instrument Detection Limit: 0.30 mg/L or less

Operating Temperature: 5 to 40 °C (41 to 104 °F)

Relative Humidity: 5 to 95% relative humidity, non-condensing

Sample Requirements

Sample Pressure: 0.5 to 30.0 psig (0.03 to 2.04 bar)

Sample Temperature: 5 to 50 °C (41 to 104 °F)

Sample Flow: 100 to 2000 mL/min. maximum

Sample Inputs: Up to two sample streams



Operation

DANGER

Handling chemical samples, standards, and reagents can be dangerous. Review the necessary Material Safety Data Sheets and become familiar with all safety procedures before handling any chemicals.

DANGER

La manipulation des échantillons chimiques, étalons et réactifs peut être dangereuse. Lire les Fiches de Données de Sécurité des Produits (FDSP) et se familiariser avec toutes les procédures de sécurité avant de manipuler tous les produits chimiques.

PELIGRO

La manipulación de muestras químicas, estándares y reactivos puede ser peligrosa. Revise las fichas de seguridad de materiales y familiarícese con los procedimientos de seguridad antes de manipular productos químicos.

GEFAHR

Das Arbeiten mit chemischen Proben, Standards und Reagenzien ist mit Gefahren verbunden. Es wird dem Benutzer dieser Produkte empfohlen, sich vor der Arbeit mit sicheren Verfahrensweisen und dem richtigen Gebrauch der Chemikalien vertraut zu machen und alle entsprechenden Material Sicherheitsdatenblätter aufmerksam zu lesen.

PERICOLO

La manipolazione di campioni, standard e reattivi chimici può essere pericolosa. La preghiamo di prendere conoscenza delle Schede Tecniche necessarie legate alla Sicurezza dei Materiali e di abituarsi con tutte le procedure di sicurezza prima di manipolare ogni prodotto chimico.

1.1 How to Use the Manuals

This instrument requires two manuals for complete operating instructions. The APA 6000™ Installation and Maintenance Manual (Cat. No. 62005-18) provides instructions for instrument installation, menu setup, operation, maintenance, and troubleshooting.

This Parameter-specific Operation Manual (Cat. No. 62029-18) contains information related to parameter specific instrument components and software functions. Descriptions of reagents and standards and their consumption rates, method of analysis, operational sequence, and bench comparison testing are all addressed in this parameter specific manual.

1.2 General Description

The APA 6000 Copper Process Analyzer is a microprocessor-controlled process analyzer designed to continuously monitor a sample water stream for copper as Cu^{2+} in clean water. Typical samples may include effluent streams from circuit board manufacturing, integrated circuit manufacturing, metal plating, and other chemical manufacturing.

Low-range and high-range models are available. The models require a different calibration standard and circuit board setting. Please see section 1.2.8 on page 8 for more information.

The analyzer can measure two sample streams. The cycle time is 4.5 minutes. A colorimetric chemical method is used to determine copper concentrations in the sample streams. Measurement unit options include ppm, ppb, mg/L, and $\mu\text{g/L}$.

The reagent containers are sized to provide reagents for 30 days of continuous operation. All reagent containers are factory-filled to 1000 mL and meet Hach's quality standards. Reagents and standards are plumbed from the reagent enclosures on the side of the instrument. All tubing enters the instrument at the ports at the bottom of the instrument bezel.

The internal instrument temperature is factory set at 40 °C (104 °F). The design of the analyzer door and instrument panel provides a small, insulated space ensuring temperature control for accurate analysis. In order for the temperature control system to function properly, the instrument door must remain closed and latched during operation.

1.2.1 Instrument Enclosure

The instrument enclosure houses various modules, the instrument's power supply, and control circuitry. Within the enclosure, a module panel separates sensitive electrical components from the wetted parts. All openings to the module panel are gasketed to protect against leakage. The module panel folds out to allow access to the electrical connections at the back of the instrument.

1.2.2 Autoburette Module

The analyzer uses a positive-displacement autoburette to measure and move fluids through the various analytical components in the instrument. The autoburette module consists of a clear acrylic block which houses a ceramic piston, a double seal for the piston, a linear actuator, a two-way solenoid valve, and control circuitry. The burette has an overall volume of 1.6 mL and can move in either direction to aspirate or dispense fluids over a 0.1 to 8.0 mL/minute range.

1.2.3 Colorimeter Module and Holding Coil

Samples are measured in a temperature-controlled single-wavelength flow cell. Light from an LED in the colorimeter passes through a 440 nm bandpass filter. The path length is 8.75 mm (0.344 inches). The temperature is controlled at 40 °C (104 °F).

The holding coil is a length of 0.030 inch ID Tefzel tubing arranged to minimize mixing. The holding coil allows low volumes of representative sample to be measured each cycle. The holding coil also effectively brings the sample and reagents to the temperature control point. Without the holding coil, “old” sample would need to be flushed from the burette. This would require at least 10x greater volume and longer analysis times, higher wastes, more sample conditioning, additional standard consumption, etc.

1.2.4 Rotary Valve Module

The rotary valve directs fluids to various components in the instrument. The valve is a selection valve with a common port at the center. An internal rotor turns to align a groove between the center port and any one of the ten available ports around the perimeter. The valve has a face-sealing design. All tubing is factory-assembled and labeled for each individual chemistry.

1.2.5 Mixer Module

The mixer module mixes reagents, sample, and standards. Fluid normally enters and exits through the bottom of the module. The openings at the top supply an overflow and a vent. The vent line is connected to the drain block. The mixer is made of acrylic and has an approximate volume of 1.0 mL. The mixer is filled, emptied, and rinsed during a typical measurement cycle. Mixing and excess air removal is accomplished via a magnetic stir bar.

1.2.6 Plumbing Diagram and Tubing Lengths

Figure 1 shows the user-replaceable tubing on the analyzer and Table 1 describes the terminal end sizes of each tube. The tubing is 0.030 inch ID Tefzel. The small diameter allows for low-volume, high-flow rates. The higher flow rate, along with properly applied sample conditioning, prevents the tubing from plugging.

General information for replacing the tubing is presented in the APA 6000 Installation and Maintenance Manual (Cat. No. 62005-18).



CAUTION

To familiarize yourself with handling precautions, dangers and emergency procedures, always review the Material Safety Data Sheets prior to handling containers, reservoirs, and delivery systems that contain chemical reagents and standards. Protective eye wear is always recommended when contact with chemicals is possible.

PRUDENCE

Pour se familiariser avec les précautions à prendre lors de la manipulation, les dangers et les procédures d'urgence, toujours lire les Fiches de Données de Sécurité des Produits avant de manipuler les récipients, les réservoirs et les systèmes de distribution contenant les réactifs chimiques et les solutions étalons. Il est toujours recommandé de porter des lunettes de protection lorsqu'un contact avec les produits chimiques est possible.

CAUIDADO

Para familiarizarse con las precauciones de manipulación, los peligros y los procedimientos de emergencia, siempre estudie las Hojas de Datos de Seguridad de los Materiales antes de manipular recipientes, depósitos y sistemas de entrega que contengan reactivos y patrones químicos. Siempre se recomienda el uso de protectores oculares cuando sea posible el contacto con productos químicos.

VORISCHT

Es wird dringend empfohlen, die Sicherheitsdatenblätter vor der Handhabung von Behältern, Tanks und Zufuhrsystemen, die chemische Reagenzien und Standardsubstanzen enthalten, aufmerksam durchzulesen, damit Sie sich mit den beim Umgang mit diesen Chemikalien notwendigen Vorsichtsmaßnahmen, Risiken und Notfallschutzmaßnahmen vertraut machen, Es wird empfohlen, in allen Situationen, in denen mit einem Kontakt mit Chemikalien zu rechnen ist, eine Schutzbrille zu tragen.

ATTENZIONE

Per familiarizzare con misure di precauzione di controllo manuale, con procedure pericolose e di emergenza, rileggere sempre le schede di sicurezza del materiale prima di maneggiare contenitori, imballaggi per spedizione che contengono reagenti chimici e standards. Si consiglia di indossare sempre gli occhiali protettivi quando è possibile un contatto con agenti chimici.

1.2.7 Vortex Sample Conditioning Block

The sample conditioning block consists of a 0.5 µm ceramic filter held within a flow block. Unfiltered sample flows around the outside of the filter and serves to continuously self-clean the filter element.

1.2.8 Copper Reagents

Calibration depends on the range chosen. The low range gives optimal accuracy below 1 mg/L and the high range gives optimal accuracy from 1–10 mg/L. Both use the same reagents, but require different calibration standards.

The low range model uses the 0- and 1.0-mg/L standards as standard 1 and standard 2, respectively. The high-range model uses the 0- and 10-mg/L standards as standard 1 and standard 2, respectively. The low range calibration is linear; the high range calibration forces the intercept through zero and is a quadratic function.

- APA Copper Reagent 1 is an acetate buffer used to control the pH at approximately 5.
- APA Copper Reagent 2 is an indicator. The indicator uses a cuprethol reagent to chelate to copper and form a yellow color.
- APA Copper Standards 1 and 2 are used for calibration. Standard 1 is a 0 mg/L as Cu²⁺ solution. Standard 2 is a 1.0 mg/L as Cu²⁺ solution for the low range instrument and a 10.0 mg/L Cu²⁺ solution for the high range instrument.
- The fifth reagent, APA Phosphoric Acid Wash, cleans the system during the Prime and Instrument Clean functions. This weak phosphoric acid solution assures the system stays free of metal precipitate buildup.

Figure 1 Plumbing Diagram for a Copper APA Analyzer

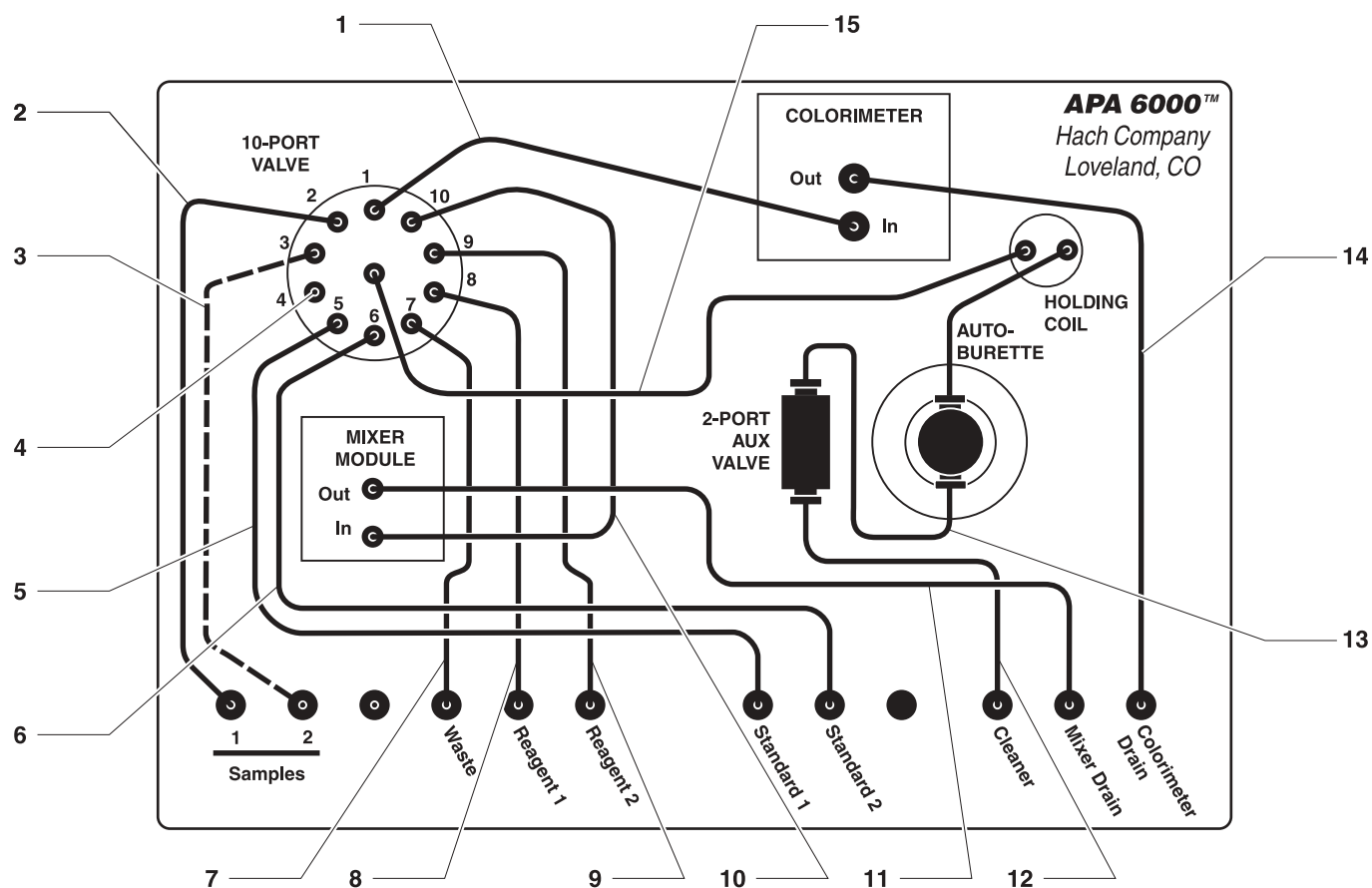

Table 1 Replacement Tubing Lengths for Figure 1

| Item | Description | Length | From... | To... |
|------|-----------------------------------|--------------------|-------------------|--------------------|
| 1 | Tefzel tubing, 0.03 ID x 0.062 OD | 7.3 in. (18.5 cm) | Port 1 | Colorimeter in |
| 2 | Tefzel tubing, 0.03 ID x 0.062 OD | 24 in. (60 cm) | Port 2 | Sample 1 |
| 3 | Blank port | — | — | — |
| 4 | Blank port | — | — | — |
| 5 | Tefzel tubing, 0.03 ID x 0.062 OD | 57 in. (145 cm) | Port 5 | Standard 1 |
| 6 | Tefzel tubing, 0.03 ID x 0.062 OD | 61 in. (152.5 cm) | Port 6 | Standard 2 |
| 7 | Tefzel tubing, 0.03 ID x 0.062 OD | 34.5 in. (87.5 cm) | Port 7 | Waste |
| 8 | Tefzel tubing, 0.03 ID x 0.062 OD | 57 in. (145 cm) | Port 8 | Reagent 1 |
| 9 | Tefzel tubing, 0.03 ID x 0.062 OD | 60 in. (152.5 cm) | Port 9 | Reagent 2 |
| 10 | Tefzel tubing, 0.03 ID x 0.062 OD | 8.3 in. (21 cm) | Port 10 | Mixer module in |
| 11 | Tefzel tubing, 0.03 ID x 0.062 OD | 27.5 in. (70 cm) | Mixer module out | Mixer drain |
| 12 | Tefzel tubing, 0.03 ID x 0.062 OD | 7 in. (17.5 cm) | Two-way NC | Wash Solution |
| 13 | Tefzel tubing, 0.03 ID x 0.062 OD | 6 in. (16 cm) | Two-way out | Autoburette bottom |
| 14 | Tefzel tubing, 0.03 ID x 0.062 OD | 26 in. (66 cm) | Back pressure out | Colorimeter drain |
| 15 | Holding Coil | 8.3 in. (21 cm) | Center port | Autoburette top |

The APA 6000™ analyzer is designed to provide reproducible results through consistent solution handling. Every step in an analysis is performed the same way each time, ensuring accurate results. Accuracy can be verified and established by measuring grab samples with a known copper concentration.

The analyzer works as follows:

1. The instrument aspirates sample into the holding coil.
2. Appropriate reagents are aspirated.
3. Sample and reagents are premixed in a mixing chamber.
4. The sample-reagent mixture is dispensed into the reaction coil, then into the detector.
5. The mixture flows through the detector, where color is measured.

2.1 Method of Analysis

The analyzer determines the copper concentration in a sample stream using the cuprethol method. Copper in the sample combines with the indicator reagent to form a yellow-colored chelant, which is directly proportional to the copper concentration. The buffer reagent ensures the optimal pH conditions for the cuprethol reaction.

The APA 6000 requires calibration to ensure instrument specifications are met. The analyzer monitors the response, and that response must be within a given range to assure the reagents are functional and the proper standards are in use. Consecutive runs must be repeatable. Repeatable runs increase confidence that the right value is used from the calibration. If these two criteria are not met, an error will result and the analyzer will not use the values obtained from the “failed” calibration.

The measurement cycle performs a colorimetric analysis to make an accurate measurement of copper in the sample stream. During normal operation the 10-port Rotary Valve rotates to various positions to move sample and reagents through the analyzer. Table 2 lists the port numbers and their function.

Table 2 Port Functions For Copper Analysis

| Port # | Function | Port # | Function |
|--------|------------|--------|------------|
| 1 | Detector | 6 | Standard 2 |
| 2 | Sample 1 | 7 | Waste |
| 3 | Sample 2 | 8 | Reagent 1 |
| 4 | Not used | 9 | Reagent 2 |
| 5 | Standard 1 | 10 | Mixer |

2.2 Reagent and Standard Consumption

The rate of reagent use depends on many factors, including the number of times the instrument cycles, calibration frequency, and the number of clean cycles. Table 3 provides the approximate volume (in mL) of the reagents consumed with each type of function per cycle.

Table 3 Reagent Consumption in mL

| Solution | Measurement | Calibration | Cleaning |
|-------------------|--------------------|--------------------|-----------------|
| Sample | 4.6 | 0 | 0 |
| Reagent 1 | 0.06 | 0.36 | 0 |
| Reagent 2 | 0.06 | 0.36 | 0 |
| Standard 1 | 0 | 11.7 | 0 |
| Standard 2 | 0 | 11.7 | 0 |
| Cleaning Solution | 0.09 | 0.6 | 9.6 |

3.1 Calibration History

This option allows you to review past calibration data.

1. Press the MENU key to start from the Main Menu.
2. Select Sensor Menu and press ENTER.
3. Select the sensor by name and press ENTER.
4. Select Calibration and press ENTER.
5. Select Cal History and press ENTER.
6. A pop-up box will appear with the calibration date and time of the seven most recent calibrations. Select Review Next Cal to step through the calibration history screens. After the last calibration, press ENTER to return to the previous menu. To exit the Cal History Menu, press EXIT.

Data displayed for the seven most recent calibrations include the concentration (in ppm) of the 0.2 (low range) or 2 (high range) standard in the first column and the concentration (in ppm) of the 0.8 (low range) or 8 (high range) standard in the second column. The values are based on the previous calibration curve applied to the standards on the current calibration. If the previous calibration was a default calibration (the first calibration) or if conditions have changed (for example, if new reagents and standards have been introduced), then a shift is expected.

3.2 Measurement Options

The analyzer allows several options for the display of concentration values. The units can be changed. Available options are ppm, ppb, mg/L, and µg/L.

Note: If a Digital Display Module (DDM) is used, select SENSOR to DISPLAY in the Network Menu to set the output of the DDM.

Important Note: Changing the displayed units will cause the stored data for the AquaTrend channel on which the units were changed to be erased.

Table 4 Initialization

| Valve Position | Volume (μL) | Autoburette Action |
|----------------|--------------------------|--------------------|
| Mixer | 600 | Aspirate |
| Waste | 600 | Dispense |
| Mixer | 600 | Aspirate |
| Waste | 600 | Dispense |
| Sample | 1000 | Aspirate |
| Between ports | 500 | Aspirate |
| Detector | 1500 | Dispense |
| Between ports | 1000 | Aspirate |
| Waste | 1600 | Dispense |

Table 5 Measurement Mode

| Valve Position | Volume (μL) | Autoburette Action |
|----------------|--------------------------|--------------------|
| Sample | 250 | Aspirate |
| Between ports | 20 | Aspirate |
| Mixer | 200 | Aspirate |
| Waste | 470 | Dispense |
| Sample | 1410 | Aspirate |
| Waste | 0 | Depressurize |
| Between ports | 90 | Aspirate |
| Detector | 400 | Dispense |
| Mixer | 1000 | Dispense |
| Mixer | 800 | Aspirate |
| Mixer | 220 | Aspirate |
| Waste | 1120 | Dispense |
| Sample | 1440 | Aspirate |
| Mixer | 0 | Depressurize |
| Reagent 2 | 60 | Aspirate |
| Mixer | 680 | Dispense |
| Mixer | 0 | Depressurize |
| Reagent 1 | 60 | Aspirate |
| Mixer | 320 | Dispense |
| Mixer | 850 | Aspirate |
| Waste | 50 | Dispense |
| Detector | 1360 | Dispense |

Section 4

Table 6 Cleaning

| Valve Position | Volume (µL) | Autoburette Action |
|----------------|-------------|--------------------|
| Between ports | 1600 | Aspirate |
| Waste | 1600 | Dispense |
| Between ports | 1600 | Aspirate |
| Mixer | 1600 | Dispense |
| Between ports | 1600 | Aspirate |
| Sample | 1600 | Dispense |
| Between ports | 1600 | Aspirate |
| Waste | 1600 | Dispense |
| Mixer | 1600 | Aspirate |
| Sample | 1600 | Dispense |
| Sample | 1600 | Aspirate |
| Waste | 1600 | Dispense |
| Sample | 1600 | Aspirate |
| Waste | 1600 | Dispense |
| Sample | 1600 | Aspirate |
| Waste | 1600 | Dispense |
| Sample | 1600 | Aspirate |
| Waste | 1600 | Dispense |
| Mixer | 1600 | Aspirate |
| Waste | 1600 | Dispense |

Table 7 Prime

| Valve Position | Volume (µL) | Autoburette Action |
|----------------|-------------|--------------------|
| Reagent 1 | 800 | Aspirate |
| Waste | 800 | Dispense |
| Reagent 1 | 400 | Aspirate |
| Waste | 400 | Dispense |
| Reagent 2 | 800 | Aspirate |
| Waste | 800 | Dispense |
| Reagent 2 | 400 | Aspirate |
| Waste | 400 | Dispense |
| Between ports | 1600 | Aspirate |
| Waste | 1600 | Dispense |
| Standard 2 | 1600 | Aspirate |
| Waste | 1600 | Dispense |
| Standard 1 | 1600 | Aspirate |
| Waste | 1600 | Dispense |
| Between ports | 1600 | Aspirate |
| Waste | 1600 | Dispense |
| Between ports | 1600 | Aspirate |
| Waste | 1600 | Dispense |

Table 8 Calibration

| Valve Position | Volume (μL) | Autoburette Action |
|----------------|--------------------------|--------------------|
| Std1 | | |
| Sample | 250 | Aspirate |
| Between ports | 20 | Aspirate |
| Mixer | 200 | Aspirate |
| Waste | 470 | Dispense |
| Standard 1 | 1510 | Aspirate |
| Between ports | 90 | Aspirate |
| Detector | 500 | Dispense |
| Standard 2 | 152 | Aspirate |
| Mixer | 1000 | Dispense |
| Mixer | 800 | Aspirate |
| Mixer | 280 | Aspirate |
| Waste | 1332 | Dispense |
| Standard 1 | 1328 | Aspirate |
| Standard 2 | 112 | Aspirate |
| Mixer | 680 | Dispense |
| Waste | 760 | Dispense |
| Mixer | 600 | Aspirate |
| Mixer | 50 | Aspirate |
| Standard 1 | 638 | Aspirate |
| Standard 2 | 152 | Aspirate |
| Mixer | 790 | Dispense |
| Mixer | 790 | Aspirate |
| Reagent 2 | 60 | Aspirate |
| Mixer | 680 | Dispense |
| Reagent 1 | 60 | Aspirate |
| Mixer | 290 | Dispense |
| Mixer | 850 | Aspirate |
| Waste | 50 | Dispense |
| Detector | 1300 | Dispense |
| Detector | 90 | Dispense |

Section 4

Table 8 Calibration (continued)

| Valve Position | Volume (μL) | Autoburette Action |
|----------------|--------------------------|--------------------|
| STD2 | | |
| Sample | 250 | Aspirate |
| Between ports | 20 | Aspirate |
| Mixer | 200 | Aspirate |
| Waste | 470 | Dispense |
| Standard 2 | 1510 | Aspirate |
| Between ports | 90 | Aspirate |
| Detector | 500 | Dispense |
| Standard 1 | 152 | Aspirate |
| Mixer | 1000 | Dispense |
| Mixer | 800 | Aspirate |
| Mixer | 280 | Aspirate |
| Waste | 1332 | Dispense |
| Standard 2 | 1328 | Aspirate |
| Standard 1 | 112 | Aspirate |
| Mixer | 680 | Dispense |
| Waste | 760 | Dispense |
| Mixer | 600 | Aspirate |
| Mixer | 50 | Aspirate |
| Standard 2 | 638 | Aspirate |
| Standard 1 | 152 | Aspirate |
| Mixer | 790 | Dispense |
| Mixer | 790 | Aspirate |
| Reagent 2 | 60 | Aspirate |
| Mixer | 680 | Dispense |
| Reagent 1 | 60 | Aspirate |
| Mixer | 290 | Dispense |
| Mixer | 850 | Aspirate |
| Waste | 50 | Dispense |
| Detector | 1300 | Dispense |
| Detector | 90 | Dispense |

5.1 Comparable Bench Methods

The procedure presented here uses the APA 6000™ Copper Reagents to create a correlation between the analyzer and a method performed in the laboratory.

Other copper procedures may be used to create that correlation. Other methods presented in *Standard Methods for the Examination of Water and Wastewater* should provide comparable results.

5.2 Bench Method Procedure

Calibration is necessary before testing samples for copper. Calibrating with Standard 1 (0.0 mg/L) and Standard 2 (low range) (1.0 mg/L) determines the blank and slope value.

Use the following hints to make calibration more efficient:

- Take all measurements at 25 °C for best accuracy.
- Use polyethylene bottles to store standards.
- If measuring high concentration samples (>5 mg/L Cu²⁺), verify the calibration line using the Standard 2 (high range) 10.0 mg/L.

Copper Calibration Procedure



1. Prepare the Zero Standard and Standard 1.

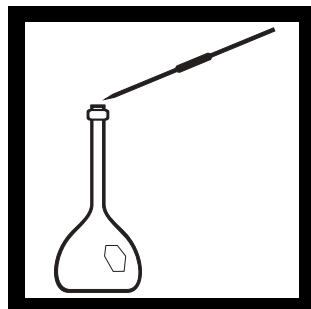

2. Using a volumetric pipet, transfer 5 mL of APA Copper Reagent 2 (indicator) into a 100-mL volumetric flask. Add about 75 mL of Zero Standard and mix.

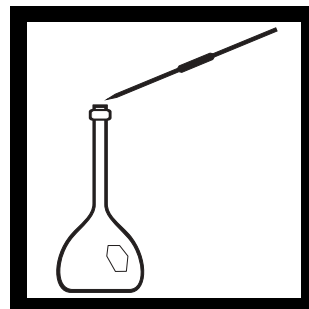

3. Add 5 mL of APA Copper Reagent 1 (buffer) to the same flask. Fill the volumetric flask to the mark with the Zero Standard. Label as “0 ppm standard”.

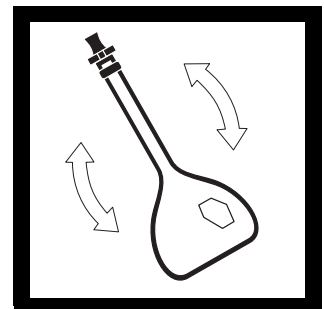

4. Invert the flask at least 7 times to mix.

Section 5

Repeat Steps 2–4 for second standard.

5. Repeat Steps 2–4, using the APA Standard 2 (low range) 1.0 mg/L in Step 2 and 3 in place of the Zero Standard. Label as “1 ppm standard”.

440 nm

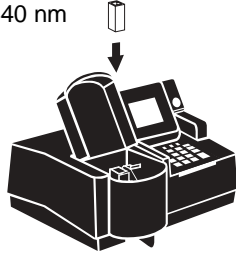

6. Using a 1-cm sample cell and a Hach DR/4000* Spectrophotometer, zero at 440 nm with deionized water.

*High concentration samples and standards will have an absorbance >1.5. Use a DR/4000 for accurate measurements at these conditions.

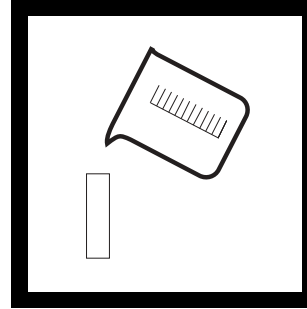

7. Within 10 minutes of adding reagents, transfer 3 mL of the 0 ppm standard into a 1-cm cell. Measure the absorbance at 440 nm.

Note: For best accuracy, rinse the cell three times with the standard before measurement.

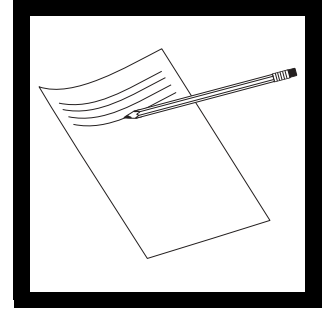

8. Record the value.

Repeat Steps 7 and 8.

9. Repeat Steps 7–8, using the 1-ppm standard.

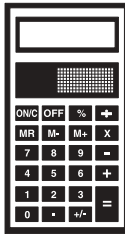

10. The blank is the absorbance value of the 0-ppm standard. The slope is the difference between the absorbance values of the 1-ppm standard and the 0-ppm standard.

Testing Samples

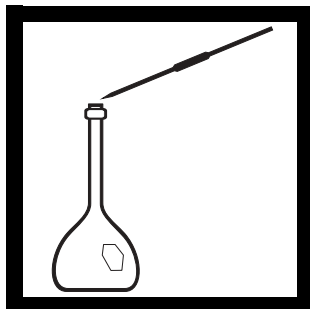

1. Using a volumetric pipet, transfer 5 mL of APA Copper Reagent 2 (indicator) into a 100-mL volumetric flask. Add approximately 75 mL of sample to the flask and mix.

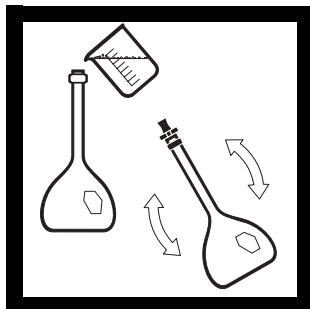

2. Add 5 mL of APA Copper Reagent 1 (buffer) to the same flask. Fill to the mark with sample. Invert the flask at least seven times to mix.

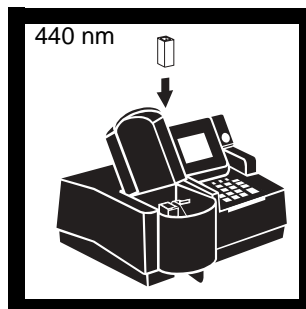

3. Within 10 minutes of adding reagents, transfer 3 mL of sample into a 1-cm cell. Measure the absorbance at 440 nm.

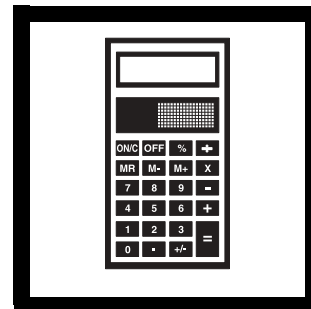

4. Calculate the total copper concentration in the sample using the following equations.

5.3 Determining Copper Concentration in Samples

Blank = Absorbance of 0 ppm standard

Slope = Abs. of 1 ppm standard – Blank absorbance

$$\text{Copper (ppm)} = \left(\frac{\text{Sample Abs.} - \text{Blank Abs.}}{\text{Slope}} \right)$$

Reagents and Standards

| Description | Unit | Cat. No. |
|--|----------|----------|
| APA 6000™ Copper Reagent 1 | 1 L..... | 27559-53 |
| APA 6000™ Copper Reagent 2 | 1 L..... | 27560-53 |
| APA 6000™ Copper Standard 1, 0.0 mg/L | 1 L..... | 27562-53 |
| APA 6000™ Copper Standard 2, low range, 1.0 mg/L | 1 L..... | 27563-53 |
| APA 6000™ Copper Standard 2, high range, 10.0 mg/L | 1 L..... | 27564-53 |
| APA 6000™ Cleaning Solution..... | 1 L..... | 26964-53 |

Required Reagents for the Bench Procedure

| | | | |
|---|-------------|----------|----------|
| APA 6000™ Copper Standard 1, 0 mg/L as Cu ²⁺ | 90 mL | 1 L..... | 27562-53 |
| APA 6000™ Copper Standard 2 (low range), 1 mg/L as Cu ²⁺ | 90 mL | 1 L..... | 27563-53 |
| APA 6000™ Copper Standard 2 (high range), see Optional Reagents and Apparatus | | | |
| APA 6000™ Copper Reagent 1 | 15 mL | 1 L..... | 27559-53 |
| APA 6000™ Copper Reagent 2 | 15 mL | 1 L..... | 27560-53 |
| Water, deionized | 10 mL | 4 L..... | 272-56 |

Required Apparatus for the Bench Procedure

| | | | |
|---|---------|--------------|----------|
| DR/4000 Spectrophotometer, UV-Vis..... | 1 | each..... | 48000-00 |
| Flask, volumetric, 100 mL, Class A | 3 | each..... | 14574-42 |
| Pipet, disposable, transfer..... | 1 | 200/box..... | 21234-00 |
| Pipet, volumetric, 5.00 mL, Class A | 2 | each..... | 14515-37 |
| Pipet bulb, 3-valve..... | 1 | each..... | 12189-00 |
| Wash Bottle, 500 mL..... | 1 | each..... | 620-11 |

Replacement Parts

| | | |
|---|-----------|----------|
| Mixer Module Assembly, APA 6000, 1-mL | each..... | 51021-00 |
| Colorimeter Assembly, APA 6000..... | each..... | 62058-02 |
| Colorimeter Module, 440 nm..... | each..... | 62060-02 |

Optional Reagents and Apparatus

| | | |
|---|--------------|----------|
| APA 6000™ Copper Standard 2 (high range), 10 mg/L as Cu ²⁺ | 1 L..... | 27564-53 |
| Bottles, polyethylene, 60 mL, storage | 12/pkg..... | 20870-71 |
| Kimwipes®, 11 x 22 cm (4.5 x 8.5 inches) | 280/box..... | 20970-00 |
| Syringe, 3 cc, Luer Lock..... | each..... | 43213-00 |

For general APA 6000 Parts and Accessories, please see the APA 6000 Process Analyzer Installation and Maintenance Manual, Cat. No. 62005-18.