



Catalog Number 62000-18

APA 6000™ High Range Hardness Process Analyzer

Operation Manual

Table of Contents

Safety Precautions	3
Specifications	4
Section 1 Instrument Overview	7
1.1 How to Use the Manuals	7
1.2 General Description	7
1.2.1 Instrument Enclosure	7
1.2.2 Autoburette Module	7
1.2.3 Colorimeter Module, Holding Coil, and Reaction Coil	8
1.2.4 Rotary Valve Module	8
1.2.5 Mixer Module	8
1.2.6 Plumbing Diagram and Tubing Lengths	8
1.2.7 Vortex Sample Conditioning Block	11
1.2.8 High Range Hardness Reagents	11
Section 2 Theory of Operation	13
2.1 Method of Analysis	13
2.2 Reagent Consumption	14
Section 3 Sequence of Instrument Events	15
Section 4 Parameter Specific Functions	22
4.1 Calibration History	22
4.2 Measurement Options	22
Section 5 Bench Method Procedure	23
5.1 Standardization	23
5.2 Standardization Procedure	23
5.3 Testing Samples for Total Hardness	24
5.3.1 Total Hardness Digital Titrator® Method	25
5.3.2 Total Hardness Buret Method	26
Section 6 Replacement Parts	27

Please read this entire manual before unpacking, setting up, or operating this instrument. Pay particular attention to all danger and caution statements. Failure to do so could result in serious injury to the operator or damage to the equipment.

To ensure the protection provided by this equipment is not impaired, do not use or install this equipment in any manner other than that which is specified in this manual.

Use of Hazard Information

If multiple hazards exist, this manual will use the signal word (Danger, Caution, Note) corresponding to the greatest hazard.

DANGER

Indicates a potentially or imminently hazardous situation which, if not avoided, could result in death or serious injury.

CAUTION

Indicates a potentially hazardous situation that may result in minor or moderate injury.

NOTE

Information that requires special emphasis.

Precautionary Labels

Read all labels and tags attached to the instrument. Personal injury or damage to the instrument could occur if not observed.



This symbol, if noted on the instrument, references the instruction manual for operation and/or safety information.



This symbol, if noted on the product, indicates the need for protective eye wear.

Specifications

Specifications are subject to change without notice.

See instrument-specific specifications in the APA 6000™ Process Analyzer Manual, Cat. No. 62005-18.

Performance

Range: 10 to 1000 mg/L as CaCO₃

Note: *If sample is outside the specified instrument range, a sample out error may occur.*

Accuracy: ±5% of reading or ±2 mg/L as CaCO₃, whichever is greater

Repeatability: ±5% of reading or ±2 mg/L as CaCO₃, whichever is greater

Response Time: For single channel instruments, less than 17 minutes for 90% response to step change at sample inlet

Cycle Time: 8.2 minutes (average)

Sample Temperature Range: 5 to 50 °C (41 to 122 °F)

Operating Temperature: 5 to 50 °C (41 to 122 °F)

Relative Humidity: 5 to 95% relative humidity, non-condensing

Sample Requirements

Sample Pressure: 0.5 to 30.0 psig (0.03 to 2.04 bar)

Sample Temperature: 5 to 50 °C (41 to 122 °F)

Sample Flow: 100 to 2000 mL/min. maximum

Sample Inputs: Up to two sample streams



Operation

DANGER

Handling chemical samples, standards, and reagents can be dangerous. Review the necessary Material Safety Data Sheets and become familiar with all safety procedures before handling any chemicals.

DANGER

La manipulation des échantillons chimiques, étalons et réactifs peut être dangereuse. Lire les Fiches de Données de Sécurité des Produits (FDSP) et se familiariser avec toutes les procédures de sécurité avant de manipuler tous les produits chimiques.

PELIGRO

La manipulación de muestras químicas, estándares y reactivos puede ser peligrosa. Revise las fichas de seguridad de materiales y familiarícese con los procedimientos de seguridad antes de manipular productos químicos.

GEFAHR

Das Arbeiten mit chemischen Proben, Standards und Reagenzien ist mit Gefahren verbunden. Es wird dem Benutzer dieser Produkte empfohlen, sich vor der Arbeit mit sicheren Verfahrensweisen und dem richtigen Gebrauch der Chemikalien vertraut zu machen und alle entsprechenden Material Sicherheitsdatenblätter aufmerksam zu lesen.

PERICOLO

La manipolazione di campioni, standard e reattivi chimici può essere pericolosa. La preghiamo di prendere conoscenza delle Schede Tecniche necessarie legate alla Sicurezza dei Materiali e di abituarsi con tutte le procedure di sicurezza prima di manipolare ogni prodotto chimico.

1.1 How to Use the Manuals

This instrument requires two manuals for complete operating instructions. The APA 6000™ Installation and Maintenance Manual (Cat. No. 62005-18) provides instructions for instrument installation, menu setup, operation, maintenance, and troubleshooting.

This Parameter-specific Operation Manual (Cat. No. 62000-18) contains information related to parameter specific instrument components and software functions. Descriptions of reagents and standards and their consumption rates, method of analysis, operational sequence, and bench comparison testing are all addressed in this parameter specific manual.

1.2 General Description

The APA 6000™ High Range Hardness Process Analyzer is a microprocessor-controlled process analyzer designed to continuously monitor a sample water stream for total hardness (calcium, magnesium, and heavy metals). Typical samples may include drinking water, raw water, cooling water, and industrial water.

The analyzer can measure one or two sample streams with a cycle time of 8.2 minutes. It uses a colorimetric chemical method to determine hardness concentrations in the sample stream. Measurement unit options include ppm, mg/L, g/gal, and Gdh (German degrees of hardness).

Data communication and retrieval is done via the AquaTrend® Interface keypad and display.

The reagent containers are sized to provide approximately 30 days of continuous operation. The reagents are factory-filled in one-liter containers and meet Hach quality standards. Prepare Reagent 2 prior to use by mixing one bottle of Indicator Powder (Cat. No. 27931-35) into 1 liter of Buffer Solution (Cat. No. 27930-53). Both powder and solution are included in the Reagent 2 Kit (Cat. No. 27936-00).

1.2.1 Instrument Enclosure

The instrument enclosure houses various modules, the instrument's power supply and control circuitry. Within the enclosure, a module panel separates sensitive electrical components from the wetted parts. All openings to the module panel are gasketed to protect against leakage. The module panel folds out to allow access to the electrical connections at the back of the instrument.

The internal instrument temperature is factory set at 50 °C (120 °F). The design of the analyzer door and instrument panel provides a small, insulated space ensuring temperature control for accurate analysis. In order for the temperature control system to function properly, the instrument door must remain closed and latched during operation.

1.2.2 Autoburette Module

The analyzer uses a positive-displacement autoburette to measure and move fluids through the various analytical components in the instrument. The autoburette module consists of a clear acrylic block which houses a ceramic piston, a double seal for the piston, a linear actuator, a two-way solenoid valve, and control circuitry. The overall volume of the burette is

Section 1

1.6 mL and it can move in either direction to aspirate or dispense fluids over a 0.1 to 8.0 mL/minute range.

1.2.3 Colorimeter Module, Holding Coil, and Reaction Coil

Samples are measured in a temperature-controlled single-wavelength flow cell. Light from an LED in the colorimeter passes through a 600 nm bandpass filter. The path length is 8.75 mm (0.344 inches). The temperature is controlled at 50 °C (120 °F).

The holding coil is a length of 0.030 inch ID Tefzel tubing arranged to minimize mixing. The holding coil allows low volumes of representative sample to be measured each cycle. The holding coil also effectively brings the sample and reagents to the temperature control point. Without the holding coil, “old” sample would need to be flushed from the burette. This would require at least 10x greater volume and longer analysis times, higher wastes, more sample conditioning, more standard consumption, etc.

This parameter also utilizes a 550 µL reaction coil. The reaction coil allows reproducible dispersion (or spreading) of the sample/indicator with the titrant (acid). As the two fluids disperse, a full range of concentrations result. This range begins with all sample/indicator then transitions to a greater concentration of titrant. Eventually, a maximum concentration of titrant is reached and as the transition continues, the titrant strength drops until only sample/indicator is present again. The reaction coil is placed between the valve and detector. After the dispersion described above occurs, the response is measured as fluids pass through the detector.

1.2.4 Rotary Valve Module

The rotary valve directs fluids to various components in the instrument. The valve is a selection valve with a common port at the center. An internal rotor turns to align a groove between the center port and any one of the ten available ports around the perimeter. The valve has a face sealing design. All tubing is factory-assembled and labeled for each individual chemistry.

1.2.5 Mixer Module

The mixer module mixes reagents with the sample or standards. Fluid normally enters and exits through the bottom of the module. The openings at the top supply an overflow and vent. The vent line is connected to the drain block. The mixer is made of acrylic and has an approximate volume of 2.0 mL. The mixer is filled, emptied, and rinsed during a typical measurement cycle. Mixing and excess air removal is accomplished via a magnetic stir bar.

1.2.6 Plumbing Diagram and Tubing Lengths

[Figure 1 on page 10](#) shows the user-replaceable tubing on the analyzer and [Table 1 on page 10](#) describes the terminal end size of each tube. The tubing is 0.030 inch ID Tefzel. The small diameter allows for low-volume and high-flow rates. A higher flow rate, along with properly applied sample conditioning, prevents the tubing from plugging.

General information for replacing the tubing is presented in the APA 6000 Installation and Maintenance Manual (Cat. No. 62005-18).

**CAUTION**

To familiarize yourself with handling precautions, dangers and emergency procedures, always review the Material Safety Data Sheets prior to handling containers, reservoirs, and delivery systems that contain chemical reagents and standards. Protective eye wear is always recommended when contact with chemicals is possible.

PRUDENCE

Pour se familiariser avec les précautions à prendre lors de la manipulation, les dangers et les procédures d'urgence, toujours lire les Fiches de Données de Sécurité des Produits avant de manipuler les récipients, les réservoirs et les systèmes de distribution contenant les réactifs chimiques et les solutions étalons. Il est toujours recommandé de porter des lunettes de protection lorsqu'un contact avec les produits chimiques est possible.

CUIDADO

Para familiarizarse con las precauciones de manipulación, los peligros y los procedimientos de emergencia, siempre estudie las Hojas de Datos de Seguridad de los Materiales antes de manipular recipientes, depósitos y sistemas de entrega que contengan reactivos y patrones químicos. Siempre se recomienda el uso de protectores oculares cuando sea posible el contacto con productos químicos.

VORISCHT

Es wird dringend empfohlen, die Sicherheitsdatenblätter vor der Handhabung von Behältern, Tanks und Zufuhrsystemen, die chemische Reagenzien und Standardsubstanzen enthalten, aufmerksam durchzulesen, damit Sie sich mit den beim Umgang mit diesen Chemikalien notwendigen Vorsichtsmaßnahmen, Risiken und Notfallschutzmaßnahmen vertraut machen. Es wird empfohlen, in allen Situationen, in denen mit einem Kontakt mit Chemikalien zu rechnen ist, eine Schutzbrille zu tragen.

ATTENZIONE

Per familiarizzare con misure di precauzione di controllo manuale, con procedure pericolose e di emergenza, rileggere sempre le schede di sicurezza del materiale prima di maneggiare contenitori, imballaggi per spedizione che contengono reagenti chimici e standards. Si consiglia di indossare sempre gli occhiali protettivi quando è possibile un contatto con agenti chimici.

Section 1

Figure 1 Plumbing Diagram for a High Range Hardness Analyzer

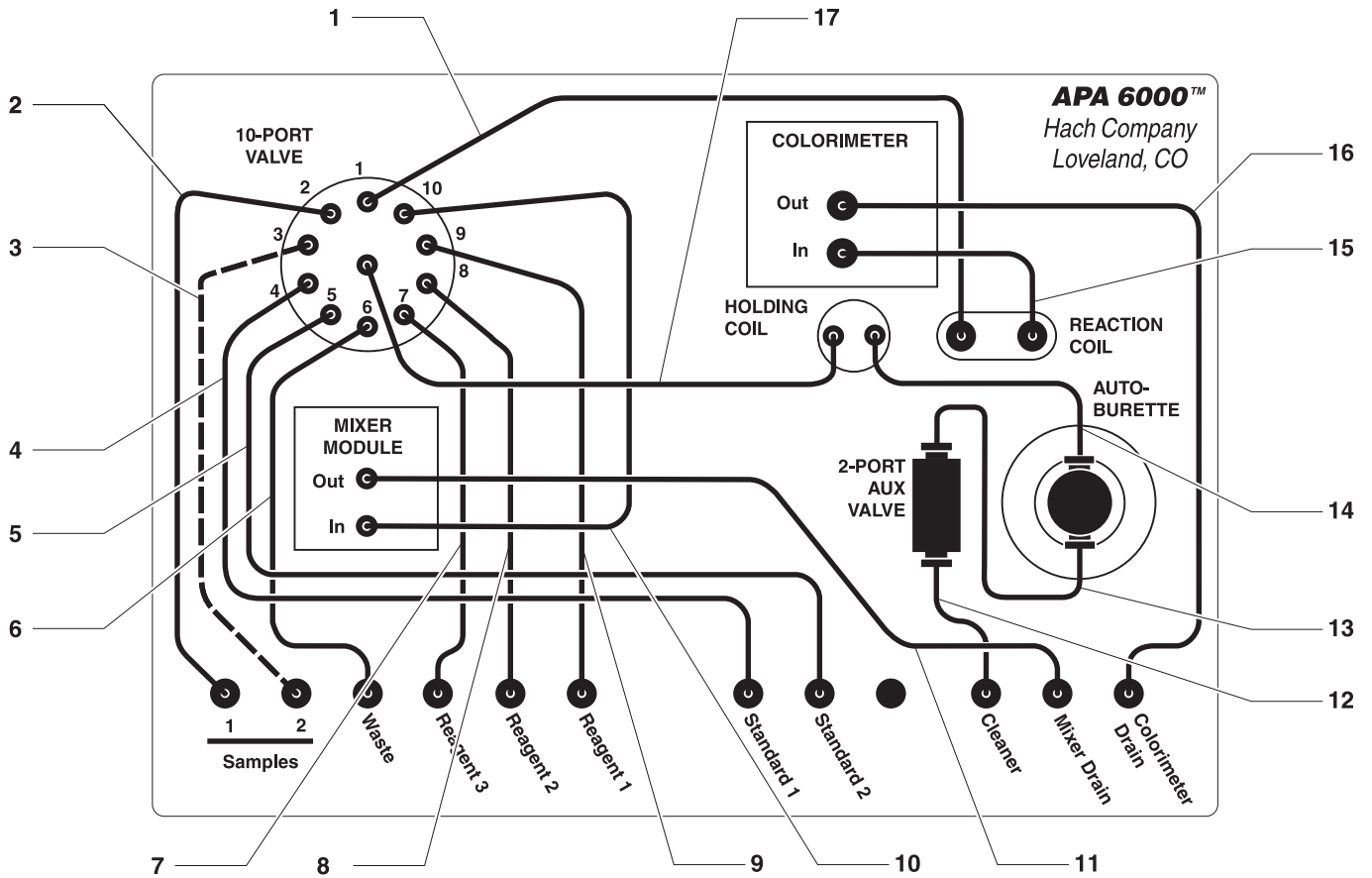

Table 1 Replacement Tubing Lengths for Figure 1

Item	Description	Length	From...	To...
1	Reaction coil - part of Temperature Control Block	Call Service	Port 1	Reaction coil
2	Tefzel tubing, 0.03 ID x 0.062 OD	60 cm (24 in.)	Port 2	Sample 1
3	Blank port	—	—	—
4	Tefzel tubing, 0.03 ID x 0.062 OD	145 cm (57 in.)	Port 4	Standard 1
5	Tefzel tubing, 0.03 ID x 0.062 OD	152.5 cm (60 in.)	Port 5	Standard 2
6	Tefzel tubing, 0.03 ID x 0.062 OD	87.5 cm (34.5 in.)	Port 6	Waste
7	Tefzel tubing, 0.03 ID x 0.062 OD	152.5 cm (60 in.)	Port 7	Reagent 3
8	Tefzel tubing, 0.03 ID x 0.062 OD	152.5 cm (60 in.)	Port 8	Reagent 2
9	Tefzel tubing, 0.03 ID x 0.062 OD	145 cm (57 in.)	Port 9	Reagent 1
10	Tefzel tubing, 0.03 ID x 0.062 OD	19 cm (7.5 in.)	Port 10	Mixer in
11	Tefzel tubing, 0.03 ID x 0.062 OD	70 cm (27.5 in.)	Mixer module out	Mixer drain
12	Tefzel tubing, 0.03 ID x 0.062 OD	17.5 cm (7 in.)	Two-way NC	Wash solution
13	Tefzel tubing, 0.03 ID x 0.062 OD	16 cm (6.3 in.)	Two-way out	Autoburette bottom
14	Tefzel tubing, 0.03 ID x 0.062 OD	30.5 cm (12 in.)	Seal wash bottom	Autoburette top
15	Tefzel tubing, 0.03 ID x 0.062 OD	Call Service	Reaction coil	Colorimeter in
16	Holding coil	Call Service	Colorimeter out	Drain
17	Common port line	17 cm (6.7 in.)	Center port	Holding coil

1.2.7 Vortex Sample Conditioning Block

The sample conditioning block consists of a 0.5 µm ceramic filter held within a flow block. Unfiltered sample flows around the outside of the filter and serves to continuously self-clean the filter element. Sample is drawn through the filter on demand. Regular maintenance of the sample conditioning is required for proper operation.

1.2.8 High Range Hardness Reagents

The APA 6000™ High Range Hardness Process analyzer uses six reagents. Each is supplied in a 1-L bottle designed to provide reagents for 30 days of continuous use.

- Reagent 1 is a masking solution that adjusts the pH of the sample.
- Reagent 2 is an indicator used to determine the endpoints of the titration. It is supplied as a kit containing a solution and a powder. The components must be mixed just before use to ensure optimal performance. Add the powder to the solution and stir or shake until the powder is completely dissolved. Once prepared, the solution is stable for 3 months.
- Reagent 3 is the titrant that reacts with the hardness in the sample.
- Standards 1 and 2 are used together to perform a multiple-point calibration. Standard 1 is a 0-mg/L as CaCO₃ sodium carbonate solution. Standard 2 is a 1000-mg/L as CaCO₃ sodium carbonate solution.
- The sixth reagent, the Cleaning Solution, cleans the system during the Prime and Instrument Clean functions. Initially, a different cleaning solution (Cat. No. 26974-53) may be used to make sure all parts are wetted.

The APA 6000™ High Range Hardness Process Analyzer is designed to provide reproducible results through consistent solution handling. Every step in an analysis is performed the same way each time, ensuring accurate results. Accuracy can be verified and established by measuring grab samples with a known concentration of analyte.

These steps describe how the analyzer works:

1. The instrument aspirates sample into the holding coil.
2. Appropriate reagents are aspirated.
3. Sample and reagents are premixed in a mixing chamber.
4. The sample-reagent mixture is dispensed into the reaction coil, then the detector.
5. The mixture flows through the detector and the color is measured.

2.1 Method of Analysis

The sample is treated with a Magnesium-CDTA masking agent at acidic pH, to eliminate both carbonate/bicarbonate and heavy metal interferences. The treated sample is then mixed with an indicator/buffer solution at a higher pH.

Some of the sample/buffer/indicator mixture is aspirated from the mixer and delivered to the detector via the reaction coil. The remainder of the mixture then a slug of EDTA titrant is aspirated and delivered to the detector via the reaction coil.

As the mixture travels through the reaction coil, the titrant becomes dispersed through the sample/buffer/indicator mixture on both sides of the titrant slug, and forms a gradient of EDTA concentration. There will be a small volume of fluid on both sides of the titrant peak and where the EDTA quantitatively binds all hardness present, the indicator changes color.

As the fluid flows through the detector, its absorbance is recorded, producing a characteristic titration peak. The peak width is determined from the inflection point on both sides of the peak. The instrument calibrates using two standards to establish a multi-point calibration curve.

In the analysis, segments of untreated sample are kept acidic to assure that no precipitation occurs in the system.

The measurement cycle follows these basic steps:

1. The analyzer rinses out the holding coil, mixer, and reaction coil in two steps with acidified sample.
2. Sample is pulled into the holding coil, followed by masking reagent.
3. This mixture is dispensed into the mixer and stirred. The mixer is filled in two strokes of the autoburette to assure only representative sample is in the mixer.

Section 2

4. A portion of the solution in the mixer is aspirated out and the buffer/indicator reagent is added. This solution aliquot and the reagent are both dispensed back into the mixer.
5. The solution in the mixer may now start to turn red.
6. Some of the solution is aspirated from the mixer and sent to the detector to prime the reaction coil.
7. The rest of the solution is aspirated from the mixer, followed by a slug of titrant reagent, and sent to the detector for titrimetric measurement using a 612 nm LED and a 600 nm filter.
8. As the titrant disperses in the reaction coil, a plug of blue solution may be seen going through the detector.

The use of inflection points in the titrimetric measurement eliminates the need for a reference measurement, even for colored samples. [Table 2](#) lists the port numbers and their function.

Table 2 Port Functions For High Range Hardness Analysis

Port #	Function	Port #	Function
1	Detector	6	Waste
2	Sample 1	7	Reagent 3
3	Sample 2	8	Reagent 2 (indicator)
4	Standard 1	9	Reagent 1
5	Standard 2	10	Mixer

2.2 Reagent Consumption

The rate of reagent use depends on many factors, including the number of times the instrument cycles, calibration frequency, and the number of clean cycles. [Table 3](#) provides the approximate volumes (in mL) of the reagents consumed with each type of function per cycle.

Table 3 Reagent Consumption in mL

Solution	Measurement	Calibration	Cleaning
Sample	5.07	0	2.0
Reagent 1	0.140	1.12	0
Reagent 2	0.16	2.56	0
Reagent 3	0.10	1.6	0
Standard 1	0	64.2	0
Standard 2	0	35.4	0
Cleaning Solution	0	0	6.8

Table 4 Initialization

Valve Position	Volume (µL)	Autoburette Action
Mixer	1000	Aspirate
Waste	1000	Dispense
Mixer	800	Aspirate
Mixer	300	Aspirate
Waste	1100	Dispense
Between ports	1600	Aspirate
Detector	1000	Dispense
Detector	600	Dispense

Table 5 Measurement Mode

Valve Position	Volume (µL)	Autoburette Action
Sample	500	Aspirate
Mask acid	50	Aspirate
Sample	450	Aspirate
Mixer	1000	Dispense
Mixer	950	Aspirate
Mixer	100	Aspirate
Waste	1050	Dispense
Sample	1500	Aspirate
Mask acid	50	Aspirate
Mixer	1000	Dispense
Mixer	950	Aspirate
Mixer	100	Aspirate
Detector	600	Dispense
Waste	1000	Dispense
Sample	1600	Aspirate
Mixer	850	Dispense
Waste	750	Dispense
Sample	1580	Aspirate
Mixer	0	Depressurize
Mask acid	20	Aspirate
Mixer	850	Dispense
Waste	750	Dispense
Sample	760	Aspirate
Mask acid	20	Aspirate
Sample	260	Aspirate
Mixer	400	Aspirate
Buffer/Indicator	160	Aspirate
Mixer	700	Dispense
Waste	900	Dispense
Mixer	1200	Aspirate
Between ports	100	Aspirate
Detector	600	Dispense
Mixer	600	Aspirate
Titant	100	Aspirate

Section 3

Table 5 Measurement Mode (continued)

Valve Position	Volume (µL)	Autoburette Action
Detector	1400	Dispense
Mixer	250	Aspirate
Waste	250	Dispense

Table 6 Cleaning

Valve Position	Volume (µL)	Autoburette Action
Mixer	1000	Aspirate
Detector	1000	Dispense
Between ports	1600	Aspirate
Detector	1600	Dispense
Between ports	1600	Aspirate
Detector	1600	Dispense
Between ports	1600	Aspirate
Mixer	1600	Dispense
Between ports	400	Aspirate
Mixer	400	Dispense
Between ports	1600	Aspirate
Detector	1600	Dispense
Mixer	1600	Aspirate
Detector	1600	Dispense
Mixer	1600	Aspirate
Detector	1600	Dispense
Sample	1600	Aspirate
Mixer	1600	Dispense
Sample	400	Aspirate
Mixer	400	Dispense
Mixer	1600	Aspirate
Detector	1600	Dispense
Mixer	400	Aspirate
Detector	400	Dispense

Table 7 Prime All

Valve Position	Volume (μL)	Autoburette Action
Between ports	1600	Aspirate
Waste	1600	Dispense
Between ports	1600	Aspirate
Waste	1600	Dispense
Mask acid	1000	Aspirate
Waste	1000	Dispense
Buffer/Indicator	1000	Aspirate
Waste	1000	Dispense
Titrant	1000	Aspirate
Waste	1000	Dispense
Between ports	1600	Aspirate
Waste	1600	Dispense
Standard 2	1000	Aspirate
Waste	1000	Dispense
Standard 1	1000	Aspirate
Waste	1000	Dispense
Between ports	1600	Aspirate
Waste	1600	Dispense

Section 3

Table 8 Calibration

Valve Position	Volume (µL)	Autoburette Action
CAL STEP 1		
Standard 1	500	Aspirate
Mask acid	50	Aspirate
Standard 1	450	Aspirate
Mixer	1000	Dispense
Mixer	950	Aspirate
Mixer	100	Aspirate
Waste	1050	Dispense
Standard 1	1500	Aspirate
Mask acid	50	Aspirate
Mixer	1000	Dispense
Mixer	950	Aspirate
Mixer	100	Aspirate
Detector	600	Dispense
Waste	1000	Dispense
Standard 1	1600	Aspirate
Mixer	850	Dispense
Waste	750	Dispense
Standard 1	1495	Aspirate
Standard 2	85	Aspirate
Mixer	0	Depressurize
Mask acid	20	Aspirate
Mixer	850	Dispense
Waste	750	Dispense
Standard 1	760	Aspirate
Mask acid	20	Aspirate
Standard 1	260	Aspirate
Mixer	400	Aspirate
Buffer/Indicator	160	Aspirate
Mixer	700	Dispense
Waste	900	Dispense
Mixer	1200	Aspirate
Between ports	100	Aspirate
Detector	600	Dispense
Mixer	600	Aspirate
Titrant	100	Aspirate
Detector	1400	Dispense
Mixer	250	Aspirate
Waste	250	Dispense

Table 8 Calibration (continued)

Valve Position	Volume (μL)	Autoburette Action
CAL STEP 2		
Standard 1	500	Aspirate
Mask acid	50	Aspirate
Standard 1	450	Aspirate
Mixer	1000	Dispense
Mixer	950	Aspirate
Mixer	100	Aspirate
Waste	1050	Dispense
Standard 1	1500	Aspirate
Mask acid	50	Aspirate
Mixer	1000	Dispense
Mixer	950	Aspirate
Mixer	100	Aspirate
Detector	600	Dispense
Waste	1000	Dispense
Standard 1	1600	Aspirate
Mixer	850	Dispense
Waste	750	Dispense
Standard 1	1410	Aspirate
Standard 2	170	Aspirate
Mixer	0	Depressurize
Mask acid	20	Aspirate
Mixer	850	Dispense
Waste	750	Dispense
Standard 1	760	Aspirate
Mask acid	20	Aspirate
Standard 1	260	Aspirate
Mixer	400	Aspirate
Buffer/Indicator	160	Aspirate
Mixer	700	Dispense
Waste	900	Dispense
Mixer	1200	Aspirate
Between ports	100	Aspirate
Detector	600	Dispense
Mixer	600	Aspirate
Titrant	100	Aspirate
Detector	1400	Dispense
Mixer	250	Aspirate
Waste	250	Dispense

Section 3

Table 8 Calibration (continued)

Valve Position	Volume (µL)	Autoburette Action
CAL STEP 3		
Standard 2	500	Aspirate
Mask acid	50	Aspirate
Standard 2	450	Aspirate
Mixer	1000	Dispense
Mixer	950	Aspirate
Mixer	100	Aspirate
Waste	1050	Dispense
Standard 2	1500	Aspirate
Mask acid	50	Aspirate
Mixer	1000	Dispense
Mixer	950	Aspirate
Mixer	100	Aspirate
Detector	600	Dispense
Waste	1000	Dispense
Standard 2	1600	Aspirate
Mixer	850	Dispense
Waste	750	Dispense
Standard 1	1580	Aspirate
Mixer	0	Depressurize
Mask acid	20	Aspirate
Mixer	850	Dispense
Waste	750	Dispense
Standard 1	760	Aspirate
Mask acid	20	Aspirate
Standard 1	260	Aspirate
Mixer	400	Aspirate
Buffer/Indicator	160	Aspirate
Mixer	700	Dispense
Waste	900	Dispense
Mixer	1200	Aspirate
Between ports	100	Aspirate
Detector	600	Dispense
Mixer	600	Aspirate
Titrant	100	Aspirate
Detector	1400	Dispense
Mixer	250	Aspirate
Waste	250	Dispense

Table 8 Calibration (continued)

Valve Position	Volume (μL)	Autoburette Action
CAL STEP 4		
Standard 2	500	Aspirate
Mask acid	50	Aspirate
Standard 2	450	Aspirate
Mixer	1000	Dispense
Mixer	950	Aspirate
Mixer	100	Aspirate
Waste	1050	Dispense
Standard 2	1500	Aspirate
Mask acid	50	Aspirate
Mixer	1000	Dispense
Mixer	950	Aspirate
Mixer	100	Aspirate
Detector	600	Dispense
Waste	1000	Dispense
Standard 2	1600	Aspirate
Mixer	850	Dispense
Waste	750	Dispense
Standard 2	1580	Aspirate
Mixer	0	Depressurize
Mask acid	20	Aspirate
Mixer	850	Dispense
Waste	750	Dispense
Standard 2	760	Aspirate
Mask acid	20	Aspirate
Standard 2	260	Aspirate
Mixer	400	Aspirate
Buffer/Indicator	160	Aspirate
Mixer	700	Dispense
Waste	900	Dispense
Mixer	1200	Aspirate
Between ports	100	Aspirate
Detector	600	Dispense
Mixer	600	Aspirate
Titrant	100	Aspirate
Detector	1400	Dispense
Mixer	250	Aspirate
Waste	250	Dispense

4.1 Calibration History

This option allows you to review past calibration data.

1. Press the MENU key to start from the Main Menu.
2. Select Sensor Menu and press ENTER.
3. Select the sensor by name and press ENTER.
4. Select Calibration and press ENTER.
5. Select Cal History and press ENTER.
6. A pop-up box will appear with the calibration date and time of the seven most recent calibrations. Select Review Next Cal to step through the “pages” of the calibration history. After the last calibration, press ENTER to return to the previous menu. To exit the Cal History Menu, press EXIT.

The calibration is cubic and is based on 50, 100, 500, and 1000 mg/L as CaCO₃ standards that are prepared by the analyzer from the 0 and 1000 mg/L as CaCO₃ standards. Data displayed for the seven most recent calibrations will include the concentration of the 50 and 500 ppm calibration points. The values are based on the previous calibration curve and applied to the standards on the current calibration.

4.2 Measurement Options

The analyzer allows several options for the display of concentration values. The units can be changed. Available options are mg/L, ppm, gr/gal, and Gdh.

Note: *If a Digital Display Module (DDM) is used, select SENSOR to DISPLAY in the Network Menu to set the output of the DDM.*

Important Note: *Changing the displayed units will cause the stored data for the AquaTrend channel on which the units were changed to be erased.*

5.1 Standardization

Standardize Reagent 3 with Standard 2 (1000 mg/L as CaCO₃) to determine the titer value of Reagent 3 before testing samples for total hardness. Perform a standardization before any sample analysis, as reagents may change over time.

5.2 Standardization Procedure

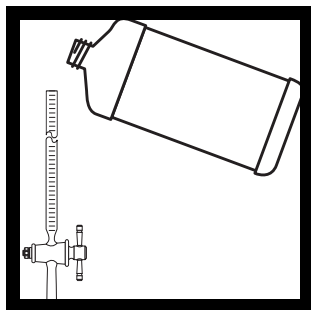

1. Fill a 25-mL buret with Reagent 3. This will be used to titrate in step 6.



2. Use a volumetric pipet to transfer 20.00 mL of Standard 2 solution into a clean 250-mL Erlenmeyer flask.

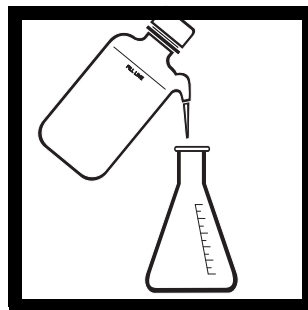

3. Dilute to about the 100-mL mark with deionized water.

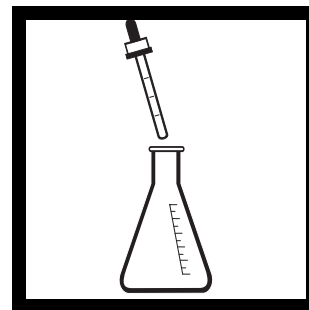

4. Using a marked dropper, add 1 mL of Reagent 1. Swirl to mix.

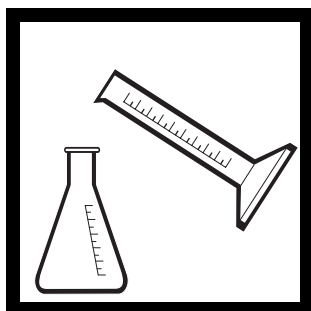

5. Using a graduated cylinder, add 8 mL of Reagent 2. Swirl to mix.

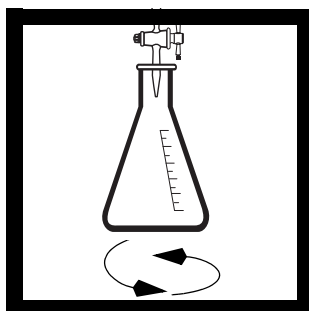

6. Swirl the flask while titrating with Reagent 3 from red to pure blue.

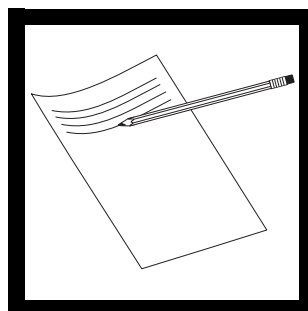

7. Record the volume of Reagent 3 required.

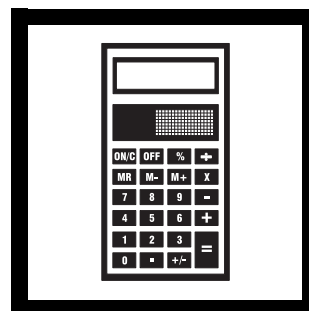

8. Calculate the titer of Reagent 3 using the equation below:

Note: Prepare Reagent 2 by mixing one bottle of Indicator Powder into 1 L of Buffer Solution. Reagent 2 can then be kept for approximately 3 months.

$$\text{Reagent 3 Titer (M)} = \frac{0.2}{\text{Reagent 3 Volume (mL)}}$$

Section 5

Repeat
steps 1-8 twice.

Average the three
values for the titer of
Reagent 3

9. Repeat steps 1-8 twice. 10. Use the average value for the titer of Reagent 3.

5.3 Testing Samples for Total Hardness

Refer to [Table 9](#) to choose between using a buret or a digital titrator, depending on the sample concentration.

Use the information in [Table 10](#) to determine the correct sample volume and pipet size for the digital titrator procedure.

Use the information in [Table 11](#) to determine the correct sample volume and pipet size for the buret titration procedure.

Table 9 Choosing a Titration Method

Sample Concentration (mg/L as CaCO ₃)	Titration Method
10 – 100	Digital Titrator
100 – 1000	Buret

Table 10 Required Sample Volume for Digital Titrator Procedure

Sample Concentration (mg/L as CaCO ₃)	Sample Volume (mL)
10 – 50	20
50 – 100	10

Table 11 Required Sample Volume for Buret Titration Procedure

Sample Concentration (mg/L as CaCO ₃)	Sample Volume (mL)
100 – 250	100
250 – 500	50
500 – 1000	20

5.3.1 Total Hardness Digital Titrator® Method

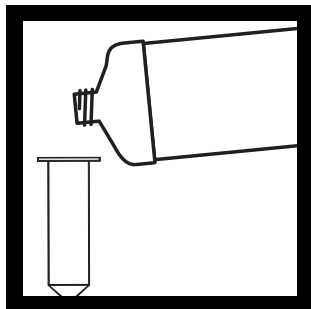

1. If a Digital Titrator is used, fill a clean and empty titration cartridge with Reagent 3.

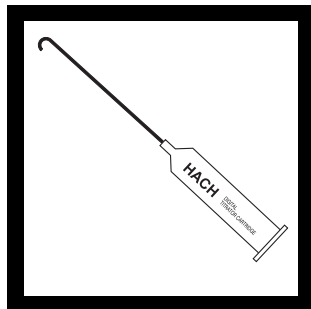

2. Insert a clean delivery tube into the titration cartridge. Attach the cartridge to the titrator body.

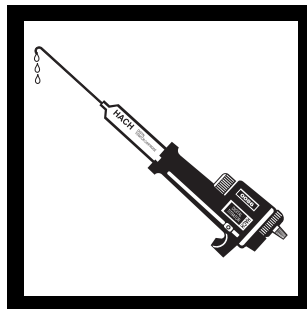

3. Turn the delivery knob to eject a few drops of Reagent 3. Reset the counter to zero and wipe the tip.

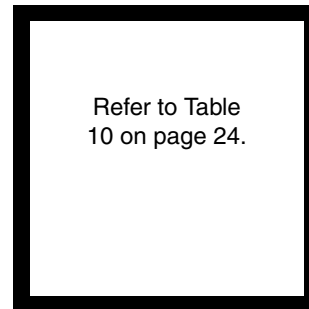

4. Refer to [Table 10](#) to choose the size of the volumetric pipet, depending on sample concentration.

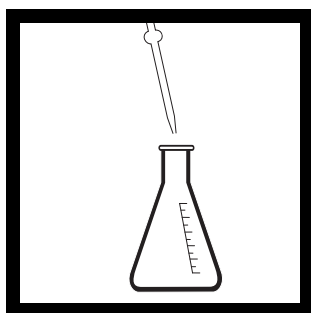

5. Using the volumetric pipet, transfer the sample volume from [Table 10](#) into a clean 250-mL Erlenmeyer flask.

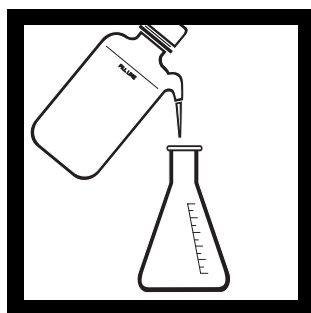

6. Dilute to about the 100-mL mark with deionized water.

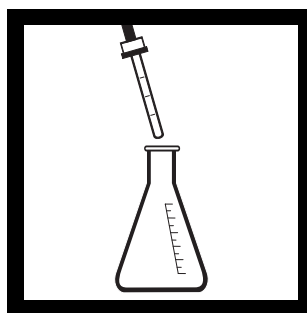

7. Using a marked dropper, add 1 mL of Reagent 1. Swirl to mix.



8. Using a graduated cylinder, add 8 mL of Reagent 2. Swirl to mix.

Note: Prepare Reagent 2 by mixing one bottle of Indicator Powder into 1 L of Buffer Solution. Reagent 2 can then be kept for approximately 3 months.

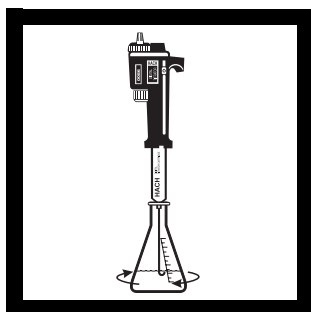

9. Swirl the flask while titrating with Reagent 3 from red to pure blue.

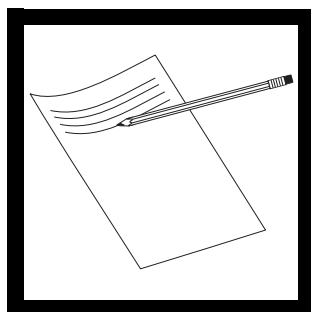

10. Record the number of digits required.

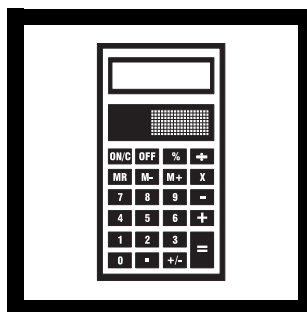

11. Calculate the sample concentration using the equation below:

$$\text{Sample Concentration (mg/L as CaCO}_3\text{)} = \frac{125 \times \text{Digits Required} \times \text{Reagent 3 Titer (M)}}{\text{Sample Volume (mL)}}$$

Section 5

5.3.2 Total Hardness Buret Method

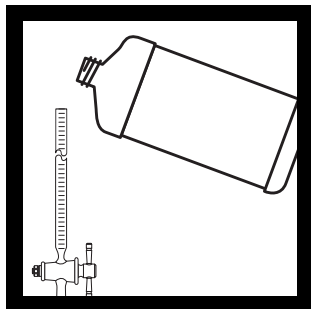

1. If a buret is used, fill a 25-mL buret with Reagent 3.

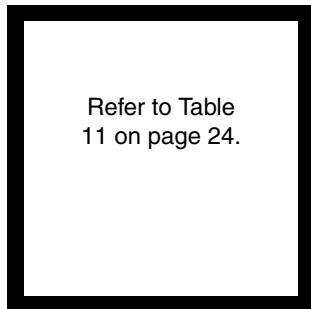

2. Refer to [Table 11](#) to choose the size of the volumetric pipet, depending on sample concentration.

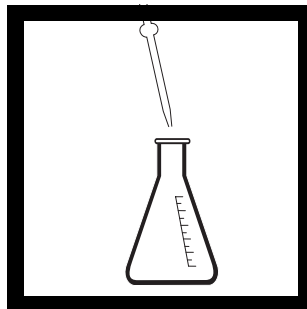

3. Using the volumetric pipet, transfer the sample volume from [Table 11](#) into a clean 250-mL Erlenmeyer flask.

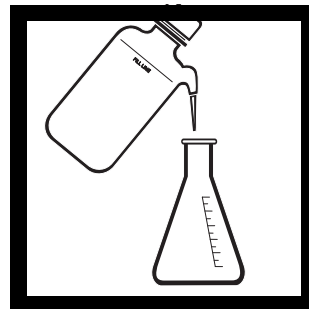

4. Dilute to about the 100-mL mark with deionized water, if necessary.

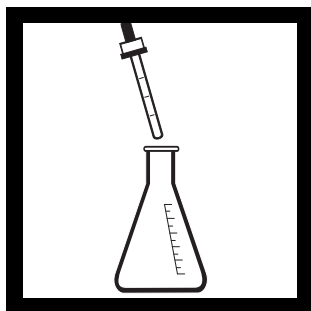

5. Using a marked dropper, add 1 mL of Reagent 1. Swirl to mix.

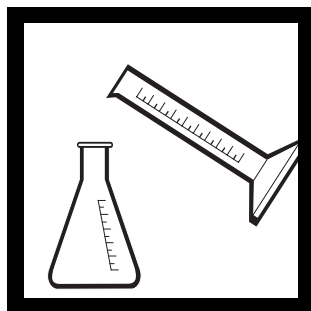

6. Using a graduated cylinder, add 8 mL of Reagent 2. Swirl to mix.

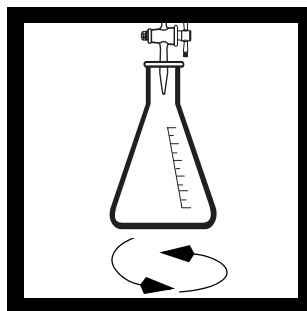

7. Swirl the flask while titrating with Reagent 3 from red to pure blue.

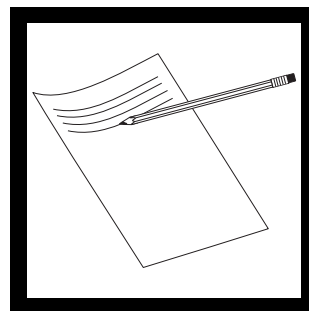

8. Record the volume required.

Note: Prepare Reagent 2 by mixing one bottle of Indicator Powder into 1 L of Buffer Solution. Reagent 2 can be kept for approximately 3 months.

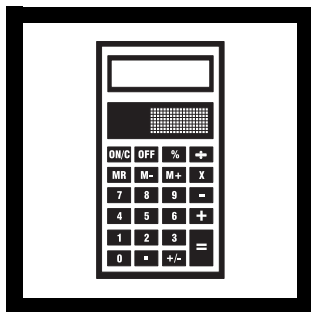

9. Calculate the sample concentration using the equation below:

$$\text{Sample Concentration (mg/L as CaCO}_3\text{)} = \frac{100000 \times \text{Volume Required (mL)} \times \text{Reagent 3 titer (M)}}{\text{Sample Volume (mL)}}$$

Required Reagents for APA 6000™ High Range Hardness Analyzer

APA 6000™ High Range Hardness Reagent 1	1 L.....	27935-53
APA 6000™ High Range Hardness Reagent 2 Kit.....	each.....	27936-00
APA 6000™ High Range Hardness Reagent 3.....	1 L.....	27937-53
APA 6000™ High Range Hardness Standard 1, 0 mg/mL.....	1 L.....	27932-53
APA 6000™ High Range Hardness Standard 2, 1000 mg/L.....	1 L.....	27933-53
APA 6000™ High Range Hardness Wash Solution	1 L.....	27934-53

Required Reagents for Bench Method

Description	Quantity Required		Cat. No.
	Per Test	Unit	
APA 6000™ High Range Hardness Reagent 1	1 mL.....	1 L.....	27935-53
APA 6000™ High Range Hardness Reagent 2 Kit.....	8 mL.....	each.....	27936-00
APA 6000™ High Range Hardness Reagent 3.....	5–20 mL.....	1 L.....	27937-53
APA 6000™ High Range Hardness Standard 2, 1000 mg/L.....	60 mL (cal. only).....	1 L.....	27933-53
Water, deionized	<100 mL.....	4 L.....	272-56

Required Apparatus for Bench Method

Buret, 25 mL, Class A, certified	*	each.....	26365-40
Cylinder, graduated, 10 mL.....	1	each.....	508-38
Delivery tubes for the Digital Titrator, 90° with J-hook	*	5/pkg.....	41578-00
Digital Titrator.....	*	each.....	16900-01
Digital Titrator cartridge, empty.....	*	each.....	14495-01
Dropper, glass with 0.5 and 1-mL mark	1	5/pkg.....	14197-05
Flask, Erlenmeyer, 250 mL	1	each.....	24894-46
Pipet, volumetric, 10 mL, Class A	*	each.....	14515-38
Pipet, volumetric, 20 mL, Class A	1 (cal. only).....	each.....	14515-20
Pipet, volumetric, 50 mL, Class A	*	each.....	14515-41
Pipet, volumetric, 100 mL, Class A	*	each.....	14515-42
Pipet bulb, 3-valve.....	1	each.....	12189-00
Wash bottle, 500 mL	1	each.....	620-11

Optional Apparatus

Bottles, storage, polyethylene, 60 mL	12/pkg.....	20870-71
Kimwipes, 11 x 22 cm (4.5 x 8.5 inches).....	280/box.....	20970-00

Replacement Parts

Mixer Module Assembly, APA 6000, 1-mL	each.....	51021-00
Colorimeter Module, 600 nm.....	each.....	62060-04

For common APA 6000 Parts and Accessories, please see the APA 6000 Process Analyzer Installation and Maintenance Manual, Cat. No. 62005-18.

* The titration method and necessary apparatus are sample concentration dependent. Refer to [Section 5.3 on page 24](#).

