

APA 6000™ Copper Analyzer



Reliable and continuous copper monitoring

For any industry in which copper monitoring is critical, the APA 6000 Copper Analyzer is an ideal choice for full-time security and long-term economy. Using the cuprethol colorimetric method, the APA 6000 assesses dissolved copper with lab accuracy – every four minutes, 24 hours a day. With only a few minutes of attention to replenish the reagents every 30 days, the APA 6000 Copper Analyzer provides true “set it and forget it” operation.

Applications

With low-range and high-range models available, Hach allows you to choose an APA 6000 Copper Analyzer to monitor dissolved copper over a range of 0.05 to 2.0 mg/L as Cu^{2+} , or 1.0 to 10.0 mg/L as Cu^{2+} .

The high-range model (1.0 to 10.0 mg/L as Cu^{2+}) is ideal for monitoring effluent streams in metal finishing operations, and printed circuit board and IC manufacturing.

The low-range model (0.05 to 2.00 mg/L as Cu^{2+}) may be used to monitor PCB/IC manufacturing effluent. It is also well-suited for process control in many copper-sensitive manufacturing processes.

Automatic 3-stream analysis, grab-sample convenience

The Hach APA 6000 Copper Analyzer can optionally monitor up to three separate sample streams with additional sample sequencing kits.

The analyzer also allows you to take periodic grab samples without interrupting sample flow. An easily accessible port allows you to introduce grab samples with a minimum of effort. Using the same port, you can verify the accuracy of the APA 6000 with a known standard addition. The instrument manual also provides bench method procedures for grab-sample correlation using APA reagents.

Principle of operation

The APA 6000 Copper Analyzer utilizes the patented CSIA (Carrierless Sequential Injection Analysis) for fluid handling. This approach allows fast analysis with low consumption of both reagents and sample. By using the sample as the dispersion carrier, the instrument makes a separate carrier liquid unnecessary – and cuts the required sample volume to about 1% of that required by other analyzers.

The instrument consists of six primary components – an autoburette, multi-position valve, mixing chamber, colorimetric detector, AquaTrend® Interface, and external case.

The autoburette first aspirates a water sample into the instrument. The reagents are then aspirated and added to the sample. The sample (or alternatively, a grab sample or standard) is pre-mixed with the reagents in the mixing chamber. The sample-reagent mixture is dispensed into the reaction coil and then through the colorimetric detector, where color intensity is measured. The concentration of copper (as Cu^{2+}) is shown on the LCD readout on the front of the case. The cycle is repeated every four minutes.

Simple menus (in English, French, German or Spanish) guide the user through each step of operation. An easy-to-use instruction manual is also included for installation, operation, calibration and troubleshooting.



The Hach APA 6000 Copper Analyzer

- Affordable copper analysis – uses colorimetric method
- Available in two ranges: low range (0.05 to 2.00 mg/L) and high range (1.0 to 10 mg/L)
- Continuous operation up to 30 days unattended
- Self-calibration, self-diagnostics, minimal maintenance
- Easily networked via the Hach AquaTrend Network using the LonWorks® protocol

**THERE'S ONLY ONE
WAY TO BE SURE**



Separate, spill-containing compartments on each side of the instrument contain all chemical reagents and standards. This allows you to change solutions without opening the enclosure and influencing the internal temperature of the instrument.

The internal instrument temperature is pre-set at the factory. The design of the analyzer door and instrument panel provides a small insulated space ensuring precise temperature control for accurate analysis.

Within the enclosure, a module panel separates sensitive electrical components from wetted parts. All openings to the enclosure are gasketed to protect against leakage.

Method of Analysis

Like many laboratory instruments, the APA 6000 Copper Analyzer uses the cuprethol method of analysis. Copper in the sample combines with the cuprethol reagent to form a yellow-colored chelant, and the intensity of this color is proportional to the copper concentration.

A buffer creates optimal pH conditions for the reaction – eliminating interference from such heavy metals as nickel, tin, lead and platinum. The instrument is also unaffected by the presence of iron up to 20 ppm.

Rugged, spill-proof enclosure

The APA 6000 is housed in a NEMA 4X(indoor)/IP66-rated enclosure that protects components from contact with chemicals and maintains a constant temperature of 40 °C for the cuprethol method. Reagents are housed in a separate, spill-proof compartment that also provides UV protection.

Genuine Hach reagents, guaranteed accuracy

Hach's rigorous quality control program ensures that both reagents and standards used with the APA 6000 Copper Analyzer meet our standards for purity and stability, so they will deliver dependable results with every test.

The system is designed for both accuracy and economy. The analyzer consumes less than 1L of each reagent per month. Reagents are easily replenished without interrupting sample flow.

Automatic, reliable operation

Operating unattended for up to 30 days, the instrument auto-calibrates, auto-cleans and self-primers. A menu-driven interface allows you to set the frequency of these functions.

Calibration

Calibration cycles can be programmed for automatic or on-demand use. Automatic calibration takes less than 35 minutes. A calibration history can easily be displayed on the analyzer's LCD display.

Multi-function displays, data outputs and network integration

The AquaTrend Controller built into the APA 6000 Copper Analyzer displays all menu choices and measurement data for up to three sample streams.



The system can also log data, display trends either numerically or graphically, and store data up to 30 days.

The APA 6000 Analyzer includes two 4-20 mA outputs and two alarm relay outputs. The operator can program the outputs anywhere within the overall analyzer range.

With optional Signal Output and Power Supply Modules, this can be expanded to 14 4-20 mA outputs and 14 alarm relay outputs. The system can be configured for up to four PID control loops to monitor and control critical processes.

Flexible datalogging capabilities allow you to graph, trend and display measurement data for the last hour, last day, or last 30 days.

An optional RS-232 interface and SIO module can provide expanded datalogging and links to PCs. Using the LonWorks® protocol, the APA 6000 can easily be linked via Hach's AquaTrend Network to other Hach instruments. Using Hach's MOD I/O interface and fast set-up software, the network can also be linked to a PLC or SCADA system with a direct, all-digital connection.

The AquaTrend Interface automatically monitors key instrument and network functions. Supervisors can easily control access to network programming functions with a four-digit password.

APA 6000 Copper Analyzer Specifications*

Ranges

Low-range: 0.05 to 2.0 mg/L as Cu²⁺

High-range: 1.0 to 10.0 mg/L as Cu²⁺

Accuracy

Low-range: ± 3% or ± 0.03 mg/L, whichever is greater

High-range: ± 5% or ± 0.05 mg/L, whichever is greater

Resolution

0.001 ppm

Repeatability

± 3% of reading or ± 0.03 mg/L, whichever is greater

Analysis method

Colorimetric, cuprethol

Cycle time

4.0 minutes (avg.)

Display

Displays data for copper (Cu²⁺) in numeric and graphic format

Sample flow

20 to 1,000 mL/min. maximum at basic water conditioning filter; 6 mL/min. maximum, filtered to 22µ or less at sample inlet block

Sample temperature

5 to 50 °C, 95% RH non-condensing

Inlet pressure

2.5 to 100 psig at basic water conditioning filter;

0.5 to 30 psig at sample inlet block

Reagent use

1 liter per month per reagent

Calibration cycle

User-selectable, from twice per day to weekly;

approx. 35 min. per cycle

Grab sample

Temperature: 5 to 50 °C

Volume: 100 mL minimum; filtered to 22µ or better

Alarms

Two SPDT alarm relays included; total of up to 14 programmable alarm relays (with optional Signal Output Modules)

Outputs

Two 4-20 mA outputs included; total of up to 14 programmable 4-20 mA outputs (with optional Signal Output and Power Supply Modules) with up to four PID control loops

Network connectivity

AquaTrend™ network, using the Lonworks® protocol

Compliance

UL, CSA and EIC safety standards, FCC and certification, European RFI standards, European EMI standards

Power requirements

95-240 VAC, 50/60 Hz

Enclosure

NEMA 4X (indoor) and IEC 529 (IP66), ABS plastic, with provision for air purge; panel-, benchtop- or wall-mountable (brackets included)

Physical dimensions

21 in. tall, 25 in. wide, 21 in. deep

(522 x 627 x 527 mm)

Weight

56 lbs. (25.5 kg)

**Subject to change without notice.*

APA 6000™ Copper Analyzer Installation

The analyzer can be bench-, wall- or panel-mounted in only a few minutes.

All necessary mounting hardware is included.

The APA 6000 Copper Analyzer should be installed as close as possible to the sampling point. A short distance between the analyzer and the sample stream allows the instrument to respond faster to changes in sample concentration.

An optional Remote AquaTrend Interface enables you to control the APA 6000 Copper Analyzer from a remote location. The interface can be positioned as far away as 1,320 feet (400 m) from the analyzer.

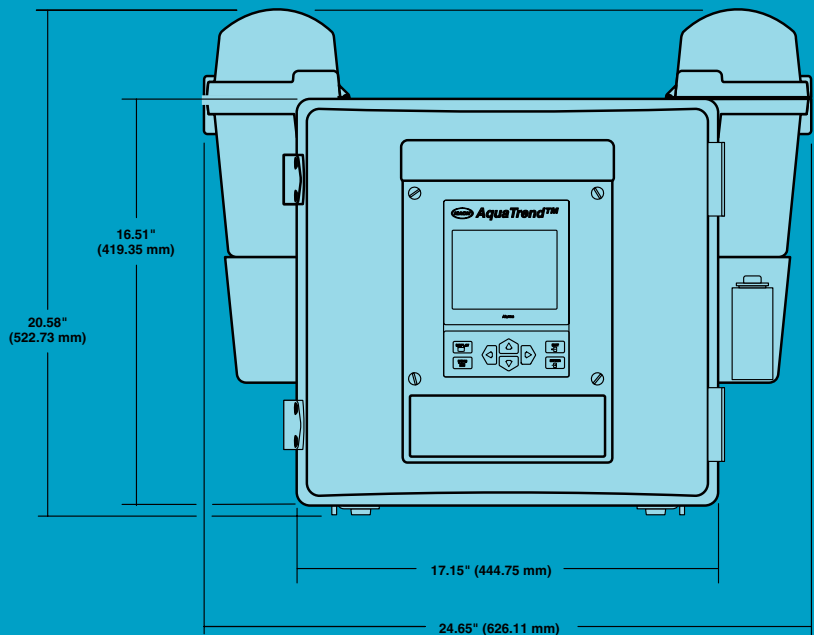

FRONT VIEW

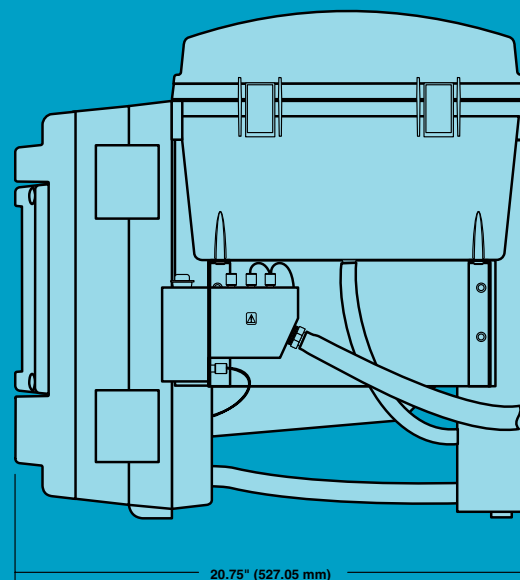

SIDE VIEW

How to Order

The APA Copper Analyzer is shipped with an Installation Kit, Maintenance Kit, Basic Sample Conditioning Kit, Manual, Quick Reference Card and a 1-month supply of reagents.

51005-10	APA 6000 High Range Copper Analyzer – 1.0 to 10.0 mg/L as Cu ⁺
51006-10	APA 6000 Low Range Copper Analyzer – 0.05 to 2.0 mg/L as Cu ⁺

Reagents

27559-53	APA 6000 Copper Reagent 1, Buffer, one 1L bottle
27560-53	APA 6000 Copper Reagent 2, Indicator, one 1L bottle
27562-53	APA 6000 Copper Standard 1, 0 mg/L, one 1L bottle
27563-53	APA 6000 Copper Standard 2 (low range), 1.0 mg/L, one 1L bottle
27564-53	APA 6000 Copper Standard 2 (high range), 10.0 mg/L, one 1L bottle
26970-53	APA 6000 Analyzer Cleaning Solution, one 1L bottle

Optional Accessories

46306-00	Power Cord, 120 VAC
46308-00	Power Cord, 240 VAC
51045-00	Sample Sequencing Kit (for optional 3-stream operation order 1 kit per additional stream)
52074-00	Serial I/O Module
51250-00	Signal Output Module
51200-00	Remote AquaTrend
52010-00	PS1201 Power Supply
51068-00	Automatic Air Backflush Kit (120 VAC)
51068-01	Automatic Air Backflush Kit (230 VAC)
51339-00	Micro Filter Kit (120 VAC)
51339-01	Micro Filter Kit (230 VAC)
Cables	
52157-00	22-gauge, 2-conductor cable, communication only, by the foot (also available in 100' to 1,000' lengths)
52158-00	20-gauge, 4-conductor cable, by the foot (also available in 100' to 1,000' lengths)



For current price information, technical support and ordering assistance, contact the Hach office or distributor serving your area.

Hach Company is
ISO 9001 Certified

In the United States, contact:

HACH Company World
Headquarters
P.O. Box 389
Loveland, Colorado 80539-0389
U.S.A.
Telephone: 800-227-4224
Fax: 970-669-2932
E-mail: orders@hach.com
Website: www.hach.com

U.S. exporters and customers
in Canada, Latin America,
sub-Saharan Africa, Asia, and
Australia/New Zealand, contact:

HACH Company World
Headquarters
P.O. Box 389
Loveland, Colorado 80539-0389
U.S.A.
Telephone: 970-669-3050
Fax: 970-669-2932
E-mail: intl@hach.com
Website: www.hach.com

In Europe, the Middle East, and
Mediterranean Africa, contact:

HACH Company
c/o Dr. Bruno Lange GmbH.
Willstätterstr. 11
DF-40549 Dusseldorf
Germany
Telephone: 49-211-52-880
Fax: 49-211-52 88231
E-mail: Hach@drlange.de

Sample Specifications: Copper Analysis

The Copper analyzer shall be a microprocessor-controlled process analyzer designed to use a cuprethol method to colorimetrically monitor soluble copper at a wavelength of 436nm. It must use the patented technique of CSIA. The measurement range shall be 0.05 to 2.0 mg/L as Cu²⁺ for the low-range analyzer or 1.0 to 10.0 mg/L as Cu²⁺ for the high-range analyzer. The low-range analyzer accuracy shall be $\pm 3\%$ or ± 0.03 mg/L, whichever is greater and the high-range analyzer accuracy shall be $\pm 5\%$ or ± 0.05 mg/L, whichever is greater. The analyzer shall display data in a numeric or graphical format. The copper analyzer shall be capable of automatic calibration, cleaning and self-priming. The analyzer shall be capable of grab-sample analysis without interrupting continuous sample flow to the analyzer.

Two user-selectable recorder/controller outputs of 4-20 mA, with expansion capability up to 14, shall be provided. Recorder output span shall be user-adjustable over the entire span of the analyzer. Two unpowered SPDT relays, also with expansion capability up to 14, shall be provided for internal alarms. Two relay contacts shall be rated for 5A resistive load at 230 VAC. Alarms may be programmed for sample concentration alarms, analyzer system warning and analyzer system shutdown.

The analyzer components shall be housed in a NEMA-4X (indoor)/IP66 plastic enclosure designed for bench-, wall- or panel-mounting. The analyzer shall be warranted for one full year against defects in materials and workmanship and shall include a 30-day supply of standards and reagents.

The analyzer shall be designed to meet UL 3101-1, CSA C22.2 No. 1010.1 and EN610101-1 (IEC 1010-1) safety standards. The analyzer shall also comply with Class A limits for radio and noise emission as specified by the FCC and EN55011 (CISPR11).